

2-Needle, Feed-off-the-arm Double Chainstitcher**高速筒型二本針二重環縫ミシン****MS-1190****MS-1190M****PARTS LIST****HOW TO MAKE USE OF THIS PARTS LIST**

1. As to "#01" and "#02" refer to the "Note" given at the bottom of the respective pages.
2. Codes on the "Qty" column
 - Each numeral indicates the number of parts required.
 - "0.1" and "2.5" indicate the length (in meters) of the respective parts.
3. Parentheses mean that the corresponding part is a subpart that constructs an assembly part.
4. Dotted lines on the Figures indicate assembly parts.

パーツリストご利用に際して

1. リストページの#01、#02等の印は、ページ下の"注記"の説明をご参照下さい。
2. 数量欄の数字は、個数を表し、0.1、2.5等の数値は、長さ(単位メートル)を表します。
3. 数量欄の()は、組部品を構成している子部品であることを意味します。
4. イラストページの-----枠は、組構成であることを意味します。

DAIKI

2-Needle Feed-off-the-arm Double-Characther

針二本付二重送りマシ

MS-1190

MS-1190M

PARTS LIST

Part No.	Part Name	Quantity	Remarks
1
2
3
4
5
6
7
8
9
10
11
12
13
14
15
16
17
18
19
20
21
22
23
24
25
26
27
28
29
30
31
32
33
34
35
36
37
38
39
40
41
42
43
44
45
46
47
48
49
50
51
52
53
54
55
56
57
58
59
60
61
62
63
64
65
66
67
68
69
70
71
72
73
74
75
76
77
78
79
80
81
82
83
84
85
86
87
88
89
90
91
92
93
94
95
96
97
98
99
100

CONTENTS

目次

1. FRAME & MISCELLANEOUS COVER COMPONENTS	1
頭部・外装関係	
2. LOOPER THREAD GUIDE COMPONENTS	3
カム系案内関係	
3. NEEDLE BAR & MAIN SHAFT COMPONENTS	5
針棒・上軸関係	
4. PRESSER BAR & LOWER SHAFT COMPONENTS	7
押さえ棒・下軸関係	
5. FEED MECHANISM COMPONENTS	9
送り関係	
6. KNEE LIFTER COMPONENTS	11
膝上げ関係	
7. THREAD STAND COMPONENTS	13
糸立装置関係	
8. TABLE OF EXCHANGING GAUGE FOR MS1190	15
交換ゲージ一覧表 MS-1190用	
9. TABLE OF EXCHANGING GAUGE FOR MS1190M	16
交換ゲージ一覧表 MS-1190M用	
NUMERICAL INDEX OF PARTS	17
索引	

1. FRAME & MISCELLANEOUS COVER COMPONENTS

頭部・外装関係

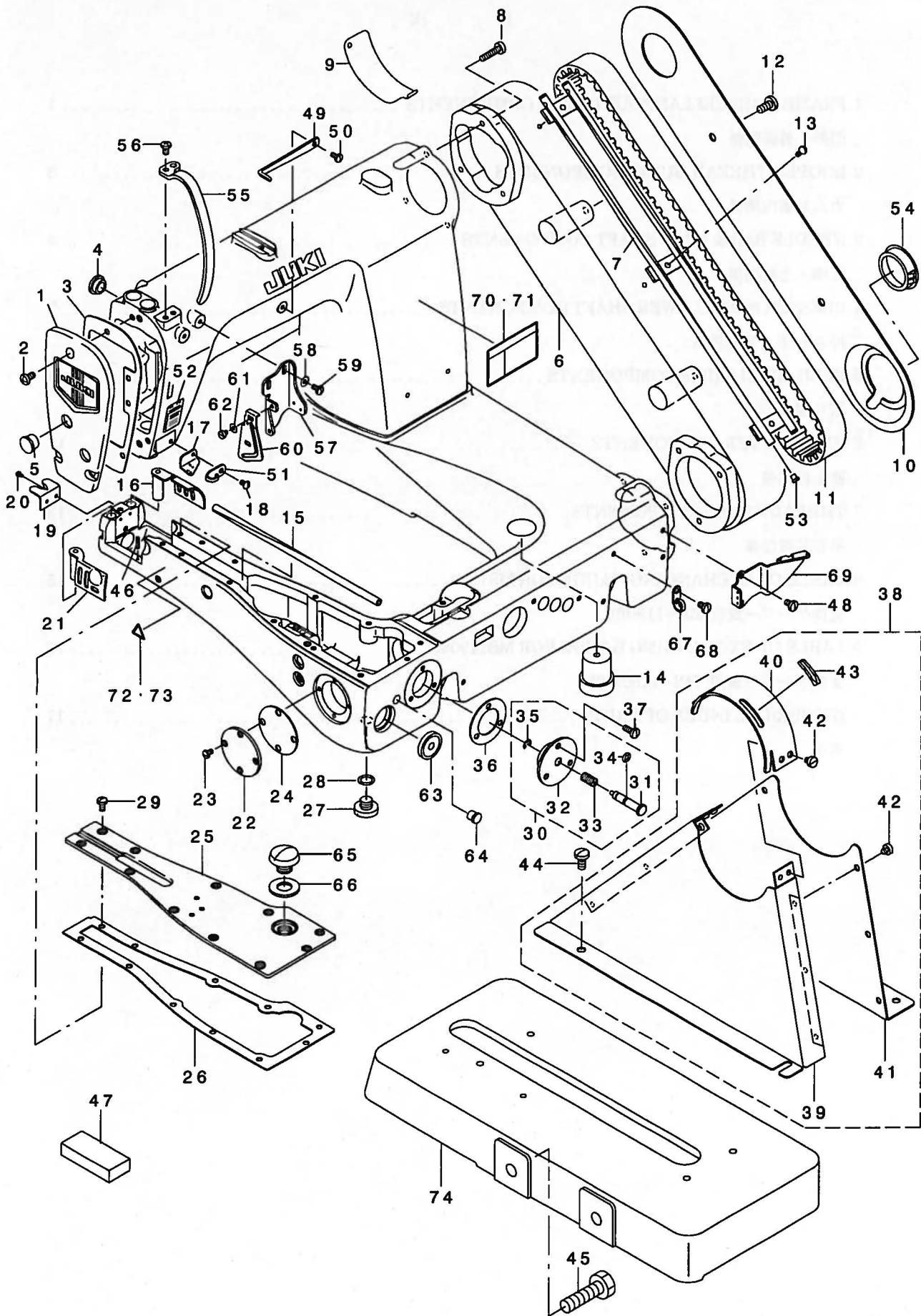

REF. NO	NOTE	PART NO.	DESCRIPTION	ヒソメイ	Qty
1		129-20955	FACE PLATE ASM.	メンタ(クミ)	1
2		SS-4120915-SP	SCREW 3/16-28 L=9	ナネン 3/16-28 L=9	3
3		129-21003	FACE PLATE GASKET	メンタハツキン	1
4		TA-1250406-RO	RUBBER PLUG D=12.5 L=4	トメシ D=12.5 L=4	1
5		TA-1250406-RO	RUBBER PLUG D=12.5 L=4	トメシ D=12.5 L=4	2
6		129-21300	SPROCKET WHEEL COVER	スプロケットハクハマカハ	1
7		129-39104	LOPPER THREAD TUBE A	シタイト トウカン(A)	1
8		SS-6122030-SP	SCREW 3/16-28 L=20	ヒラネン 3/16-28 L=20	6
9	#03	129-21201	SPROCKET WHEEL AUXILIARY COVER	スプロケットハクハマカハ ヨカハ	1
10		129-21409	SPROCKET WHEEL COVER PLATE	スプロケットハクハマカハ - フタ	1
11		B1219-019-000	TIMING BELT	タイミング ベルト	1
12		SS-7151210-SP	SCREW 15/64-28 L=12	マルヒラネン 15/64-28 L=12	2
13		SS-4091010-SP	SCREW 9/64-40 L=10	ナネン 9/64-40 L=10	2
14		B1156-019-000	RUBBER CUSHION, C	ホツンゴAC	1
15		B1157-019-000	LOOPER THREAD TUBE (C)	シタイト トウカン C	1
16		B1160-019-0AA	LOOPER COVER ASM. RIGHT	ルハ - ミキマト イタツゴウウ	1
17	#01	129-25608	FRAME THREAD GUIDE, NEEDLE	ハリイ トアンナイ	1
18		SS-3090610-SP	SCREW 9/64-40 L=6	マルネン 9/64-40 L=6	1
19		129-22704	CHAIN CUTTER BLADE	イトキリ	1
20		SS-3060410-SP	SCREW 3/32-56 L=4	マルネン 3/32-56 L=4	2
21		B1162-019-0AA	LOOPER COVER ASM. LEFT	ルハ - ヒダリマト イタツゴウウ	1
22		B1805-019-000	FRONT BUSHING COVER	シタツク マメタカ フタ	1
23		SS-5090610-SP	SCREW 9/64-40 L=6	トラスネン 9/64-40 L=6	4
24		B1806-019-000	GASKET	シタツク マメタカ ハツキン	1
25		129-22357	BED COVER ASM.	ハダト マト イタ(クミ)	1
26		129-22506	BED COVER GASKET	マト イタ ハツキン	1
27		SS-7740740-SP	SCREW 3/8-28 L=6.5	マルヒラネン 3/8-28 L=6.5	2
28		RO-0681901-00	RUBBER RING	オリツク	2
29		SS-5110810-SP	SCREW 11/64-40 L=8	トラスネン 11/64-40 L=8	11
30		129-32158	PUSH BUTTON GUIDE ASM.	オウホ タンツク クウ(クミ)	1
31		129-32000	PUSH BUTTON STUD	オウホ タンツク	(1)
32		129-32109	PUSH BUTTON GUIDE	オウホ タンツク クウ	(1)
33		B1622-541-000	SPRING	オウホ タン ハネ	(1)
34		RO-0401002-10	O-RING	オリツク	(1)
35		RE-0400000-KO	E-RING 4	Eリング 4	(1)
36		B1634-191-000	GASKET	オウホ タンツク ハツキン	1
37		SS-7111120-SP	SCREW 11/64-40 L=10.5	マルヒラネン 11/64-40 L=10.5	3
38		B1104-191-0AA	BELT COVER ASM.	ハカカハ (クミ)	1
39		B1104-191-0AA	BELT COVER	ハカカハ	(1)
40		B1104-191-0AB	TOP COVER	トップカハ	(1)
41		B1104-191-0AC	BELT COVER PLATE	ハカカハ - フタ	(1)
42		SS-6110480-SP	SCREW 11/64-40 L=4.3	ヒラネン 11/64-40 L=4.3	(10)
43		CM-5003000-01	DIRECTION LABEL	ホウコウハカ	(1)
44		SS-7151210-SP	SCREW 15/64-28 L=12	マルヒラネン 15/64-28 L=12	4
45		SS-9284043-CP	SCREW 7/16-16 L=40	ロツクカネ 7/16-16 L=40	2
46		PS-0200082-KH	SPRING PIN	スプリングピン	1
47		B3512-191-000	FELT	フェルト	1
48		SS-7110710-SP	SCREW 11/64-40 L=7	マルヒラネン 11/64-40 L=7	2
49	#02	B1165-026-000	TENSION RELEASE LEVER	チュウカン イコルルハ	1
50	#02	SS-7090710-SP	SCREW 9/64-40 L=6.8	マルヒラネン 9/64-40 L=6.8	1
51	#02	B1130-051-000	FRAME THREAD GUIDE, MIDDLE	イトアンナイ	1
52		129-20807	NEEDLE DISPLAY SHEEL	ハリ ヒョウシ ヂール	1
53		B1124-804-000	THREAD GUIDE, SMALL	イトミチ ヲウ	4
54		129-21607	RUBBER PLUG	ハクハマカハ - フタ セン	1
55		129-23207	TENSION COVER	テンビシカハ	1
56		SS-4110815-SP	SCREW 11/64-40 L=8	ナネン 11/64-40 L=8	2
57	#01	129-34303	BRACKET	テンビシカハ トリツクガイ	1
58	#01	WP-0371016-SD	WASHER 3.7X8X1	ヒラネン 3.7X8X1	2
59	#01	SS-7090710-SP	SCREW 9/64-40 L=6.8	マルヒラネン 9/64-40 L=6.8	2
60	#01	129-34402	THREAD TAKE UP GUIDE	テンビシカハ ト	1
61	#01	WP-0320501-SE	WASHER 3.2X7.0X0.5	ヒラネン 3.2X7.0X0.5	2
62	#01	SS-6080410-SP	SCREW 1/8-44 L=4	ヒラネン 1/8-44 L=4	2
63		107-04203	OIL POT WINDOW	オイルポット	1
64		TA-0850604-RO	RUBBER PLUG	トメシ	1
65		SS-5820540-SP	SCREW 1/2-28 L=5.0	トラスネン	1
66		B1140-019-000	GASKET	アゲラダメ ハツキン	1
67		110-18603	ARM THREAD GUIDE B	アームイトアンナイ B	1
68		SS-7110710-SP	SCREW 11/64-40 L=7	マルヒラネン 11/64-40 L=7	1
69		129-40102	LOOPER THREAD GUIDE PLATE	シタイト アンナイイタ	1
70	#04	CM-3002001-01	SAFETY LABEL, 1(SMALL).	アンビシラハ 1(ショウ)	1
71	#05	CM-3002001-A1	SAFETY LABEL, 3 (SMALL).	アンビシラハ 3(ショウ)	1
72	#06	CM-3002000-01	ATTENTION SEAL	エビカガ チョウイター(16)	1
73	#04	CM-3002000-C1	CAUTION LABEL	メスチョウイター(16)	1
74		129-43700	BELT GUARD INSTALLING BASE	ハカカハ	1

NOTE (注記)

#01....FOR MS-1190
 #02....FOR MS-1190M
 #03....FOR EXCEPT V0
 #04....FOR DOMESTIC USE
 #05....FOR EXCEPT JE AND DOMESTIC USE
 #06....FOR JE

MS-1190用
 MS-1190M用
 V0なしの時使用
 国内用
 JE,国内用を除く
 JE用

2. LOOPER THREAD GUIDE COMPONENTS

カム系案内関係

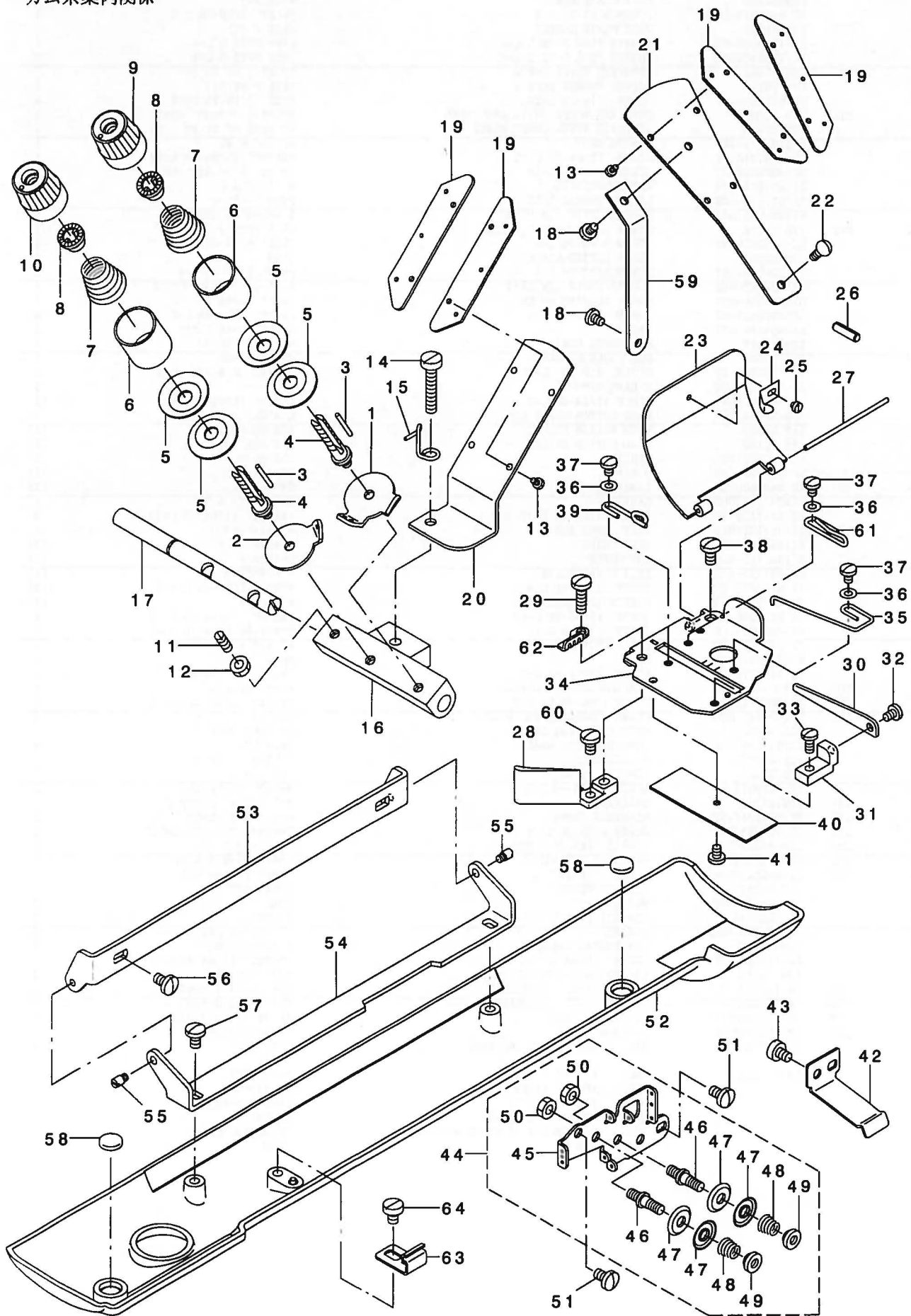

3. NEEDLE BAR & MAIN SHAFT COMPONENTS

針棒・上軸関係

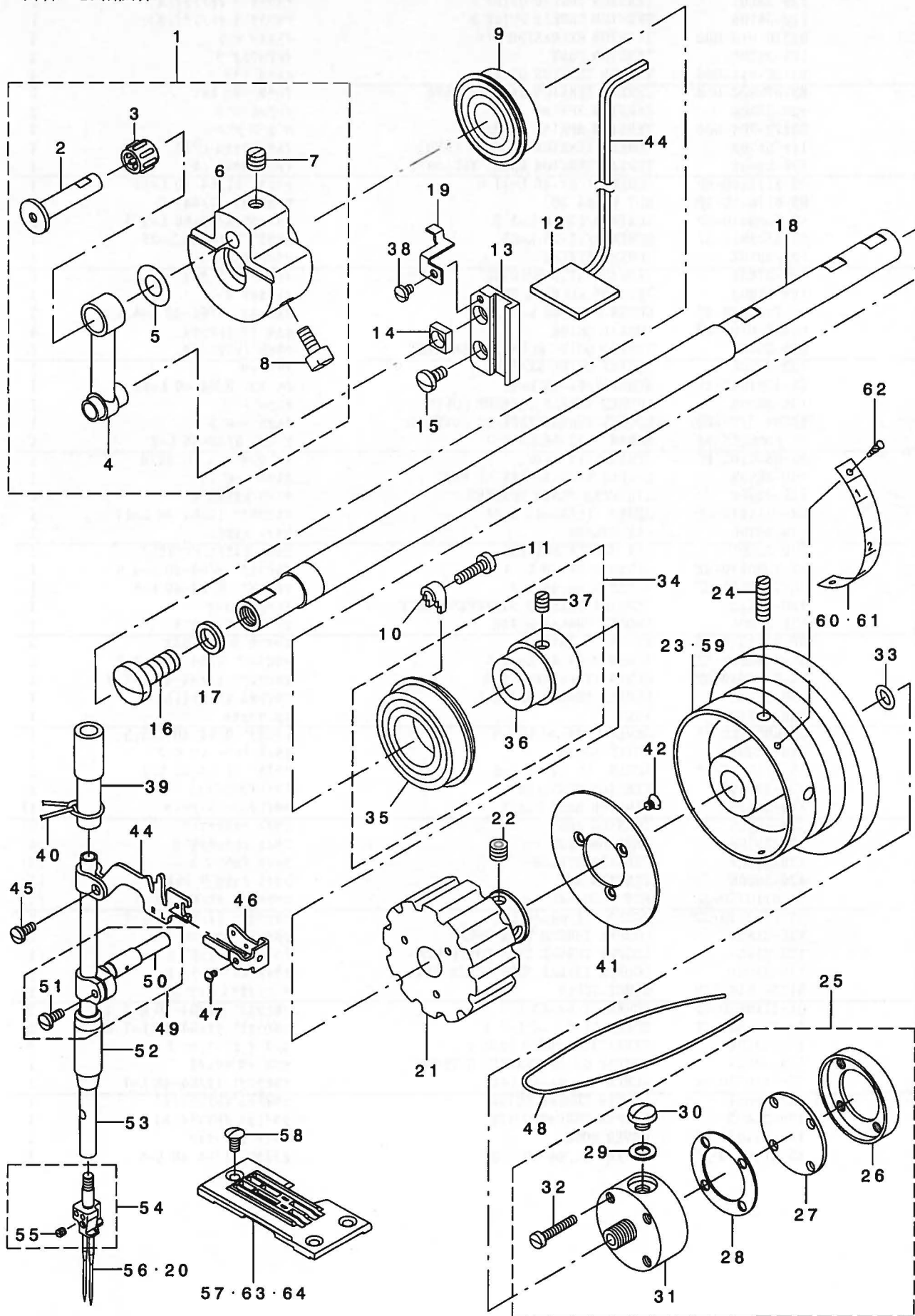

REF. NO	NOTE	PART NO.	DESCRIPTION	ヒソメイ	Qty
1		B1207-191-AB0	COUNTERWEIGHT ASM.	ツリアイネモリ クミ	1
2		B1209-019-OA0	NEEDLE BAR CRANK PIN ASM.	ハリネ - クランクピン クミ	(1)
3	#01	B1236-125-BA0	NEEDLE BUSHING ASM.	ニートルハ フリソク	(1)
4		B1408-038-000	NEEDLE BAR CRANK ROD, B	ハリネ - クランクロッド B	(1)
5		B1208-019-000	WASHER	ハリネ - クランクロッド サカネ	(1)
6		B1207-191-A00	COUNTERWEIGHT	ツリアイネモリ	(1)
7		SS-8660610-TP	SCREW 1/4-40 L=6	トメネジ 1/4-40 L=6	(2)
8		SS-6151220-SP	SCREW 15/64-28 L=11.5	ヒラネジ 15/64-28 L=11.5	(2)
9		B1202-512-000	MAIN SHAFT BUSHING, FRONT	ウツク クマエハ フリソク	1
10		129-24809	METAL PRESSER	メタルオサエ	3
11		SS-6111610-SP	SCREW 11/64-40 L=16	ヒラネジ 11/64-40 L=16	3
12		B3510-019-000	OIL FELT	カンリュ - フェルト	1
13		B1412-038-000	SLIDE BLOCK GUIDE	コロ アンナイダ イ	1
14		B1411-019-000	SLIDE BLOCK GUIDE	ハリネ - タキ アンナイコロ	1
15		SS-7120910-SP	SCREW 3/16-28 L=9	マルヒラネジ 3/16-28 L=9	2
16		SS-7740740-SP	SCREW 3/8-28 L=6.5	マルヒラネジ 3/8-28 L=6.5	1
17		B1222-019-000	PACKING	ウツク クマエハ トメ カワハ ツキン	1
18		129-24502	MAIN SHAFT	ウツク ク	1
19		129-43106	OIL WICK PRESSER	エツソオサエ	1
20	#01	MC-2630008-00	NEEDLE B-64 80	ハリ B-64 80	2
21		129-24916	SPROCKET WHEEL A	スプロケットハガ ルマ(A)	1
22		SS-8660522-TP	SCREW 1/4-40 L=4.5	トメネジ 1/4-40 L=4.5	2
23	#02	129-25202	HAND WHEEL	ハズミグ ルマ	1
24		SS-8152030-SP	SCREW 15/64-28 L=20	トメネジ 15/64-28 L=20	2
25		B3501-019-OA0	OIL CUP BODY ASM.	オイルカップ クミ	1
26		B3504-019-000	OIL CUP BODY CAP RETAINER	オイルカップ フタ	(1)
27		B3502-019-000	OIL CUP BODY CAP	オイルカップ マトイタ	(1)
28		B3503-019-000	OIL CUP BODY CAP GASKET	オイルカップ マトイタ ハツキン	(1)
29		B3508-019-000	WASHER	アブラチュウ - ネジ ハツキン	(1)
30		SS-5660440-SP	SCREW 1/4-40 L= 4.0	トラスネジ 1/4-40 L=4	(1)
31		B3501-019-000	OIL CUP BODY	オイルカップ タイ	(1)
32		SS-6092120-SP	SCREW 9/64-40 L=21.2	ヒラネジ 9/64-40 L=21.2	(4)
33		RO-0982401-00	RUBBER RING	オリソク	1
34		129-24767	BUSHING REAR ASM.	アトメタル(クミ)	1
35		B1203-512-000	BUSHING, REAR	ウツク ク ウツロハ フリソク	(1)
36		129-24718	BUSHING	メタル フツ	(1)
37		SS-8150710-SP	SCREW 15/64-28 L=7	トメネジ 15/64-28 L=7	(2)
38		SS-7090530-SP	SCREW 9/64-40 L= 4.5	マルヒラネジ 9/64-40 L=4.5	1
39		B1402-019-000	NEEDLE BAR BUSHING, UPPER	ハリネ - ウツメタル	1
40		CQ-3030000-00	OIL WICK	エツソ	0.23
41		129-25004	PULLEY PLATE	ア - リ ア - レート	1
42		SS-1090510-SP	SCREW 9/64-40 L=5	チラネジ 9/64-40 L=5	3
43		B3541-012-000	OIL WICK	カンリュ - エツソ	1
44		129-34006	TAKE UP TENSION	テンピン	1
45		SS-7090910-TP	SCREW 9/64-40 L= 8.5	マルヒラネジ 9/64-40 L=8.5	1
46		129-34105	TAKE UP THREAD EYELET	テンピン イトアンナイ	1
47		SS-3060410-SP	SCREW 3/32-56 L=4	マルネジ 3/32-56 L=4	1
48		CQ-2520000-00	OIL WICK	エツソ	1
49		B1409-019-0B0	NEEDLE BAR CLAMP ASM.	ハリネ - タキ クミ	1
50		B1418-019-000	FELT	ハリネ - タキ キュ - エルト	(1)
51		SS-7090910-SP	SCREW 9/64-40 L= 8.5	マルヒラネジ 9/64-40 L=8.5	(1)
52		B1404-026-000	NEEDLE BAR BUSHING, LOWER	ハリネ - ヌタメタル	1
53		B1401-019-000	NEEDLE BAR	ハリネ -	1
54	#04	129-25954	NEEDLE CLAMP 3/16 ASM.	ハリトメ 3/16(クミ)	1
55		SS-8080310-TP	SCREW 1/8-44 L=2.8	トメネジ 1/8-44 L=2.8	(2)
56	#01	MTV-640N1200	NEEDLE TVX64-NY#12	ハリ TVX64-NY #12	2
57	#04	129-23405	THROAT PLATE(3/16)	ハリイタ (3/16)	1
58		SS-2110920-TP	SCREW 11/64-40 L=8.5	マルチラネジ 11/64-40 L=8.5	3
59	#03	129-81502	HAND WHEEL	ハズミグ ルマ	1
60	#02	129-25301	SCALE PLATE	ハズミグ ルマ メモリイタ	1
61	#03	129-81601	SCALE PLATE	ハズミグ ルマ メモリイタ	1
62		B1161-227-000	RIVET	トメトヨ (キンイロ)	2
63	#05	129-23306	THROAT PLATE 1/8	ハリイタ(カラカンタイクヨウ 1/8)	1
64	#06	129-80900	THROAT PLATE 1/8	ハリイタ(カラカンタイクヨウ 1/8M)	1

NOTE (注記)

#01...SELECTIVE PART
 #02...FOR MS-1190
 #03...FOR MS-1190M
 #04...REFER TO THE TABLE OF EXCHANGINGPARTS ON P.15
 #05...OPTION (FOR MS-1190)
 #06...OPTION (FOR MS-1190M)

選択部品
 MS-1190用
 MS-1190M用
 15へーシングの交換部品を参照下さい。
 オプション(MS-1190用)
 オプション(MS-1190M用)

4. PRESSER BAR & LOWER SHAFT COMPONENTS

押さえ棒・下軸関係

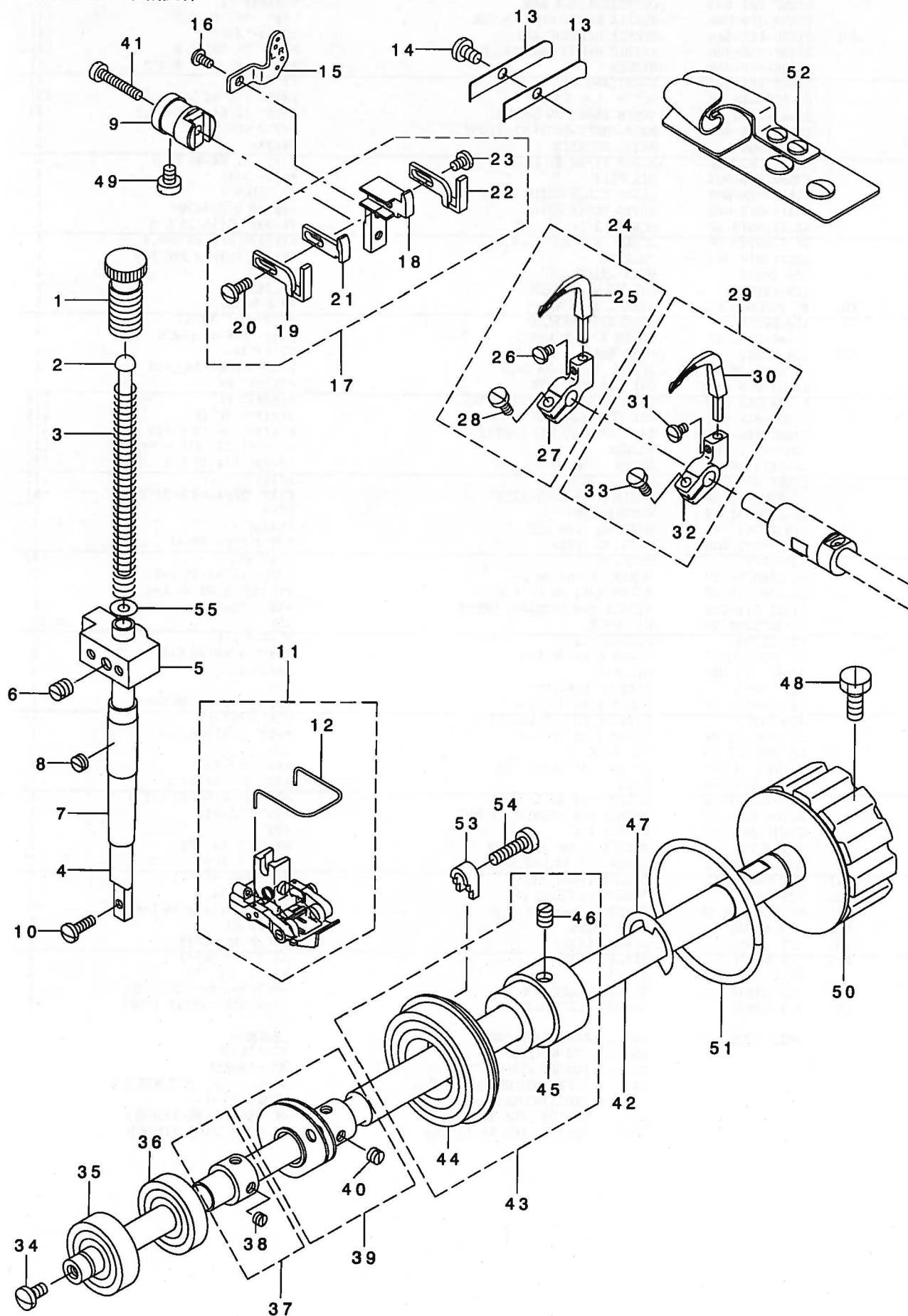

REF. NO.	NOTE	PART NO.	DESCRIPTION	ヒ ヨ メ イ	Qty
1		B1509-191-000	PRESSER SPRING REGULATOR	オサエ チョ-セツネジ	1
2		B1510-191-000	PRESSER GUIDE BAR	オサエ アンナイホ -	1
3		B1505-191-000	PRESSER SPRING	オサエ チョ-セツハネ	1
4		B1501-191-000-A	PRESSER BAR	オサエホウ	1
5		110-06004	PRESSER BAR GUIDE BRACKET	オサエホウ ウタキ	1
6		SS-8660610-TP	SCREW 1/4-40 L=6	トメネジ 1/4-40 L=6	1
7		B1502-541-000	PRESSER BAR BUSHING, LOWER	オサエホウ - ヲタメタル	1
8		SS-8150310-SP	SCREW 15/64-28 L= 3.4	トメネジ 15/64-28 L=3.4	1
9		129-42801	NEEDLE GUARD HOLDER	ハリウケ チョウセツツク	1
10		SS-7091110-TP	SCREW 9/64-40 L=10.5	マルヒラネジ 9/64-40 L=10.5	1
11	#01	129-27760	PRESSER FOOT ASM. 3/16	オサエ 3/16(クミ) ユツユツヨウ	1
12		129-29600	NEEDLE GUARD	ニートルカート	(1)
13		B1166-019-000	LOOPER COVER SPRING	マトイタハネ	1
14		SS-7110710-SP	SCREW 11/64-40 L=7	マルヒラネジ 11/64-40 L=7	1
15		129-42900	LOOPER THREAD EYELET	ルハ - イトアンナイ	1
16		SS-6090510-SP	SCREW 9/64-40 L=5	ヒラネジ 9/64-40 L=5	1
17		129-42355	NEEDLE GUARD ASM.	ハリウケ(クミ)	1
18		129-42306	REAR NEEDLE HOLDER, R	ウツロハリウケ (R)	(1)
19		129-42603	FRONT NEEDLE HOLDER, L	マエハリウケ(L)	(1)
20		SS-7090910-SP	SCREW 9/64-40 L= 8.5	マルヒラネジ 9/64-40 L=8.5	(1)
21		129-42504	REAR NEEDLE HOLDER, L	ウツロハリウケ(L)	(1)
22		129-42603	FRONT NEEDLE HOLDER, L	マエハリウケ(L)	(1)
23		SS-7090520-SP	SCREW 9/64-40 L= 4.5	マルヒラネジ 9/64-40 L=4.5	(1)
24	#01	129-40557	LOOPER, R 3/16 ASM.	ルハ - (R) 3/16(クミ)	1
25	#01	129-40508	LOOPER, R 3/16	ルハ - (R) 3/16	(1)
26		SS-4080620-TP	SCREW 1/8-44 L=6	ナハネジ 1/8-44 L=6	(1)
27		129-41100	LOOPER HOLDER, 1	ルハ - ヲツウウデ (1)	(1)
28		SS-6090910-TP	SCREW 9/64-40 L=9	ヒラネジ 9/64-40 L=9	(1)
29	#01	129-41456	LOOPER, L3/16 ASM.	ルハ - (L) 3/16(クミ)	1
30	#01	129-41407	LOOPER, L 3/16	ルハ - (L) 3/16	(1)
31		SS-4080620-TP	SCREW 1/8-44 L=6	ナハネジ 1/8-44 L=6	(1)
32		129-42009	LOOPER HOLDER, 2	ルハ - ヲツウウデ (2)	(1)
33		SS-6090910-TP	SCREW 9/64-40 L=9	ヒラネジ 9/64-40 L=9	(1)
34		SS-7110830-SP	SCREW 11/64-40 L= 7.5	マルヒラネジ 11/64-40 L=7.5	1
35		B1802-019-000	BALL BEARING, FRONT	シタツクマエハアリソク	1
36		B1803-019-000	BALL BEARING, INTERMEDIATE	シタツクナカハアリソク	1
37		B1808-019-0A0	SLEEVE ASM.	シタツクナカメタルフツツククミ	1
38		SS-8110310-SP	SCREW 11/64-40 L= 2.8	トメネジ 11/64-40 L=2.8	(2)
39		129-37256	LOOPER THREAD CAM ASM.	シタイトカム(クミ)	1
40		SS-8110310-sp	SCREW 11/64-40 L= 2.8	トメネジ 11/64-40 L=2.8	(2)
41		SS-6092120-SP	SCREW 9/64-40 L= 21.2	トメネジ 9/64-40 L=21.2	1
42		129-33610	HOOK DRIVING SHAFT	シタツク	1
43		129-24767	BUSHING REAR ASM.	アトメタル(クミ)	1
44		B1203-512-000	BUSHING, REAR	ウツツクウツロハアリソク	(1)
45		129-24718	BUSHING	メタルフツツク	(1)
46		SS-8150710-SP	SCREW 15/64-28 L=7	トメネジ 15/64-28 L=7	(2)
47		RE-1200000-K0	E-RING 12	Eカトメワ 12	1
48		SS-9151440-CP	SCREW 15/64-28 L=14	ロツカクホルト 15/64-28 L=14	2
49		SS-6110610-TP	SCREW 11/64-40 L=6	ヒラネジ 11/64-40 L=6	1
50		129-33719	SPROCKET WHEEL B	スプロケットハク ルマ(B)	1
51		B1214-019-000	SPROCKET RING	スプロケットリング	1
52	#01	MAM-2950CCAA	HOLDER 3/16A	ホルダ - 3/16A	1
53		129-24809	METAL PRESSER	メタルオサエ	3
54		SS-6111610-SP	SCREW 11/64-40 L=16	ヒラネジ 11/64-40 L=16	3
55		WP-0550800-SP	WASHER 5.5X10X0.8	ヒラザカネ 5.5X10X0.8	1

NOTE (注記) #01...REFER TO THE TABLE OF EXCHANGING ON P.15

15ページの交換部品一覧表をご参照下さい。

5. FEED MECHANISM COMPONENTS

送り関係

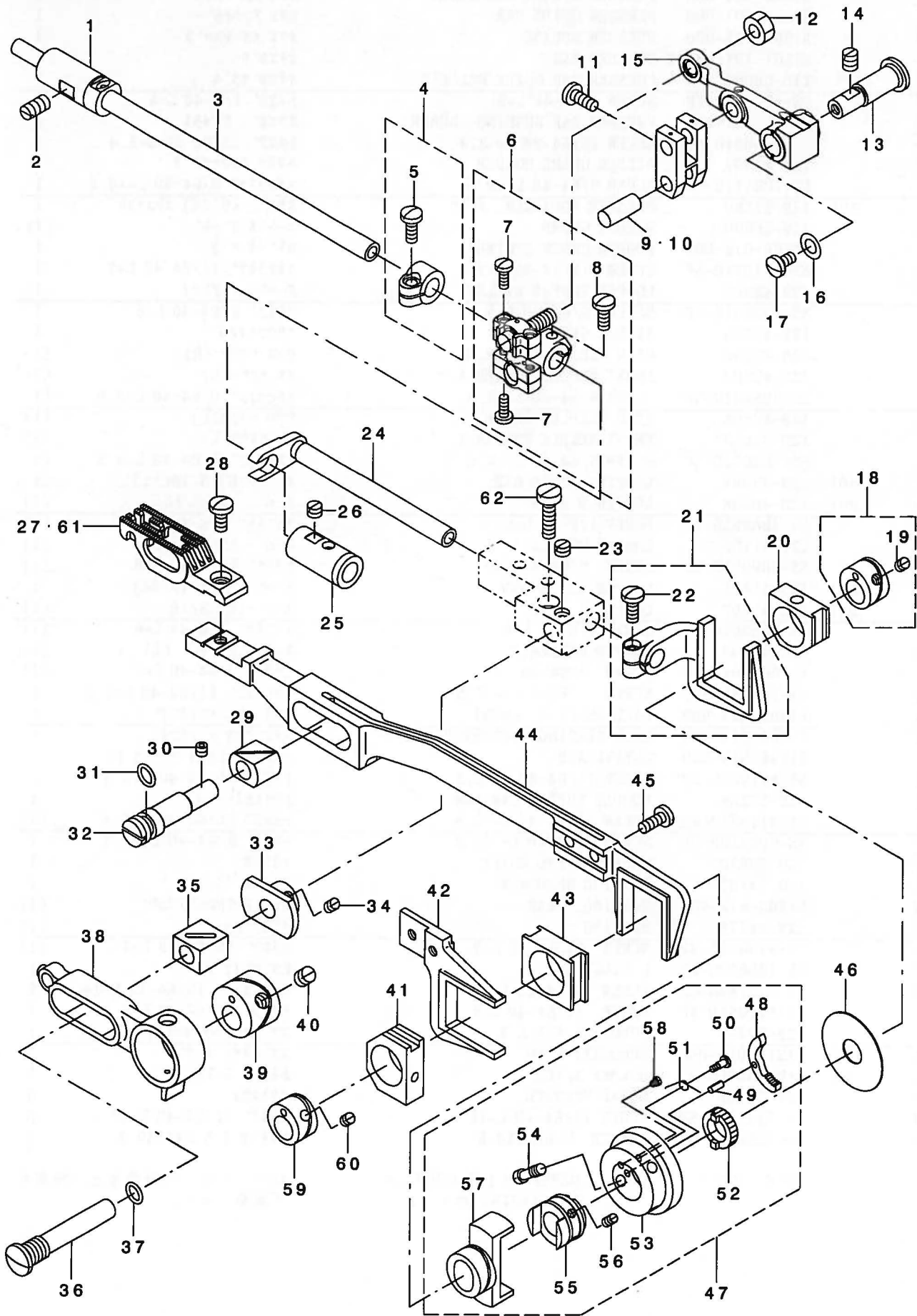

From the library of: Diamond Needle Corp

REF. NO	NOTE	PART NO.	DESCRIPTION	ヒソメイ	Qty
1		B2502-019-000	BUSHING, FRONT	ル-ハ' シ' ク マメタル	1
2		SS-8151150-SP	SCREW 15/64-28 L=10.5	トメネジ' 15/64-28 L=10.5	1
3		B2501-019-000	LOOPER ROCKER SHAFT	ル-ハ' シ' ク	1
4		B2505-019-0A0	CONNECTION CRANK ASM.	ゼ' ソコ' カン オキエカナク' クミ	1
5		SS-7111110-TP	SCREW 11/64-40 L=10.5	マルヒラネジ' 11/64-40 L=10.5	(1)
6		B2109-019-0A0	FEED ROCKER CONNECTING ROD ASM	ヨ-ト' - レンケツカン' クミ	1
7		SS-7090920-SP	SCREW 9/64-40 L= 8.5	マルヒラネジ' 9/64-40 L=8.5	(4)
8		SS-7111110-TP	SCREW 11/64-40 L=10.5	マルヒラネジ' 11/64-40 L=10.5	(1)
9	#01	B2116-191-00A	FEED CONNECTING LINK PIN	レンケツウデ' ビ' ソ(A)	2
10	#01	B2116-191-00B	FEED CONNECTING LINK PIN	レンケツウデ' ビ' ソ(B)	2
11		SS-7080510-TP	SCREW 1/8-44 L=4.5	マルヒラネジ' 1/8-44 L=4.5	4
12		NS-6150310-SP	NUT 15/64-28	ロツカクナツト 15/64-28	1
13		B2107-019-000	FEED ROCKER SHAFT	ヨ-ト' - カン' シ' ク	1
14		SS-8150710-SP	SCREW 15/64-28 L=7	トメネジ' 15/64-28 L=7	1
15		129-35011	FEED ROCKER	ヨウト' ウカン	1
16		B2122-019-000	WASHER	ヨ-ト' - カン' シ' ク' サ' ガ' ネ	1
17		SS-7110830-SP	SCREW 11/64-40 L= 7.5	マルヒラネジ' 11/64-40 L=7.5	1
18		B2006-019-0A0	LOOPER AVOIDING ECCENTRIC CAM	ゼ' ソコ' オクリ' ハソソソカム' クミ	1
19		SS-8110410-TP	SCREW 11/64-40 L= 3.5	トメネジ' 11/64-40 L=3.5	(2)
20		B1635-191-000	SLIDE BLOCK	ゼ' ソコ' カン' フタマダサキ	1
21		B2004-191-0A0	LOOPER AVOIDING SHAFT ASM.	ゼ' ソコ' カン' フタマダ' クミ	1
22		SS-7111110-TP	SCREW 11/64-40 L=10.5	マルヒラネジ' 11/64-40 L=10.5	(1)
23		SS-8150410-SP	SCREW 15/64-28 L=4	トメネジ' 15/64-28 L=4	1
24		B2001-019-000	LOOPER AVOIDING SHAFT	ゼ' ソコ' シ' ク	1
25		B2503-019-000	LOOPER ROCKER SHAFT BUSHING, R	ル-ハ' シ' ク' ウツロメタル	1
26		SS-8150410-SP	SCREW 15/64-28 L=4	トメネジ' 15/64-28 L=4	1
27	#02	129-32307	FEED DOG	オクリ	1
28		SS-7621040-SP	SCREW 3/16-32 L= 9.5	マルヒラネジ' 3/16-32 L=9.5	1
29		B1610-019-000	SLIDE BLOCK	スイハイオクリ' フタマダ' カクコ' マ	1
30		SS-8110422-TP	SCREW 11/64-40 L=4	トメネジ' 11/64-40 L=4	1
31		RO-0611801-00	RUBBER RING	オリソク'	1
32		B1608-019-000-A	FEED BAR ECCENTRIC HINGE PIN	ジ' ヨ-ゲ' オクリ' リヨ- チヨ-セツジ' ク	1
33		B2108-019-000	FEED ROCKER SLIDE BLOCK STOPPE	カクコ' マ' シ' ク' フテイタ	1
34		SS-8110510-SP	SCREW 11/64-40 L=5	トメネジ' 11/64-40 L=5	2
35		B2105-019-000	FEED ROCKER SLIDE BLOCK	ヨ-ト' - カン' カクコ' マ	1
36		B2106-019-000	FEED ROCKER SLIDE BLOCK PIN	ヨ-ト' - カン' カクコ' マ' ジ' ク	1
37		RO-0952001-00	RUBBER RING	オリソク'	1
38		B2101-191-000-A	LOOPER AVOID LEVER	ヨウト' ウクト' ウカン	1
39		129-35102	FEED ROCKER ECCENTRIC	ヨウト' ウカン' ハソソソカム	1
40		SS-8660610-TP	SCREW 1/4-40 L=6	トメネジ' 1/4-40 L=6	2
41		B1635-191-000	SLIDE BLOCK	ゼ' ソコ' カン' フタマダサキ	1
42		B1602-019-000	FEED LIFTING FORKED CONNECTION	ジ' ヨ-ゲ' オクリ' フタマダ	1
43		B1606-191-000	FEED ECCENTRIC SLIDE BLOCK	スイハイオクリ' フタマダサキ	1
44		B1601-019-000	FEED BAR	スイハイ' オクリ' フタマダ	1
45		SS-7111110-TP	SCREW 11/64-40 L=10.5	マルヒラネジ' 11/64-40 L=10.5	2
46		129-31903	BODY CAP	チヨウセツタイ' フテイタ	1
47		129-31465	FEED ECCENTRIC BASE ASM.	オクリ' リヨウ' チヨウセツタイ'(ソウクミ)	1
48		B1624-191-000	RATCHET PAWL	ラチエツトオサエ	(1)
49		PS-0250081-K0	SPRING PIN 2.5X8	スア' リソク' ビ' ソ	(1)
50		B1626-191-000	SCREW	ラチエツトオサエ' ハ' ネ' トメネジ'	(1)
51		B1625-191-000	RATCHET PAWL SPRING	ラチエツトオサエ' ハ' ネ	(1)
52		B1623-191-000	RATCHET GEAR	ラチエツトキ' ヤ	(1)
53		129-31408	FEED ECCENTRIC	オクリ' リヨウ' チヨウセツタイ	(1)
54		129-31606	SCREW	オクリ' リヨウ' チヨウセツタイ' トメネジ'	(1)
55		129-31507	FEED ECCENTRIC BODY	スイハイオクリ' チヨウセツジ' ク	(1)
56		SS-8110410-TP	SCREW 11/64-40 L= 3.5	トメネジ' 11/64-40 L=3.5	(2)
57		B1621-261-000-A	FEED ECCENTRIC GUIDE	スイハイオクリ' カム	(1)
58		129-31705	SCREW	ユルミ' トメネジ'	(1)
59		B2006-019-000	LOOPER AVOIDING ECCENTRIC	ゼ' ソコ' オクリ' ハソソソカム	1
60		SS-8110410-TP	SCREW 11/64-40 L= 3.5	トメネジ' 11/64-40 L=3.5	2
61	#03	129-32208	FEED DOG 1/8	オクリ'(カラカン' タイ' シ' ク' ヨウ' 1/8)	1
62		SS-6121840-SP	SCREW 3/16-28 L=18	ヒラネジ' 3/16-28 L=18	1

NOTE (注記)

#01...SELECTIVE PART
 #02...REFER TO THE TABLE OF EXCHANGING PARTS ON P.15
 #03...OPTION

選択部品
 15へ' - シ' の交換部品
 一覧表をご参照下さい。
 オプション

6. KNEE LIFTER COMPONENTS

膝上げ関係

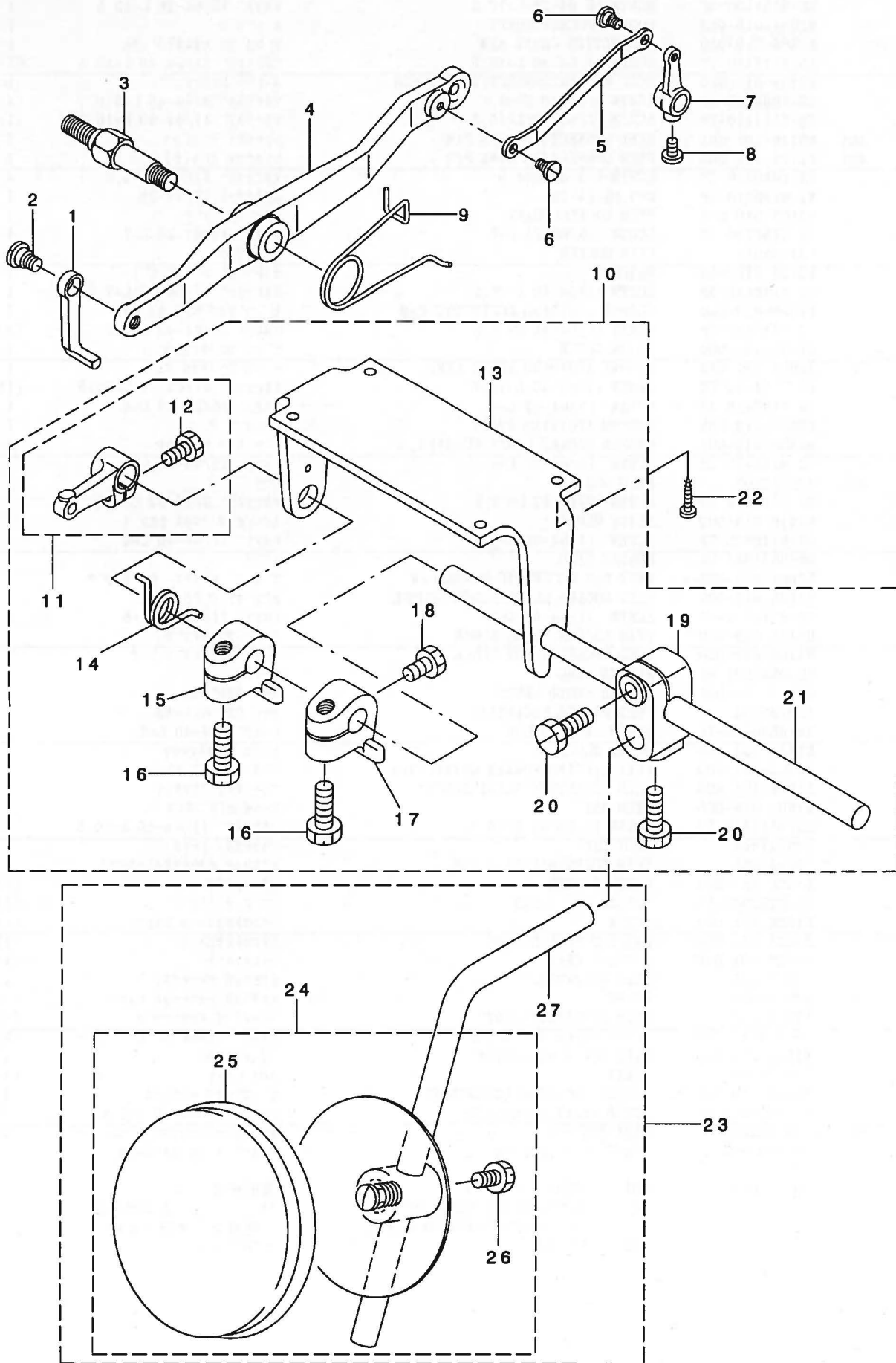

REF. NO.	NOTE	PART NO.	DESCRIPTION	ヒソメイ	Qty
1		B2322-019-000	PRESSER BAR LIFTING BRACKET LI	オサエアケ テコ	1
2		SD-0790431-SP	HINGE SCREW D= 7.94 H= 4.3	ダソネジ D=7.94 H=4.3	1
3		B3701-019-000	HINGE SCREW	ヒザアケ テコ ダソネジ	1
4		B2319-191-00A	PRESSER BAR LIFTING LEVER	ヒザアケ テコ	1
5		129-38502	LEVER	イトユルメ レハ-	1
6		SD-0450211-SP	HINGE SCREW D= 4.50 H= 2.1	ダソネジ D=4.5 H=2.1	2
7		B2317-019-000	TENSION RELEASING SHAFT CRANK	イトユルメ ウテ	1
8		SS-7110710-SP	SCREW 11/64-40 L=7	マルヒラネジ 11/64-40 L=7	1
9		B2321-019-000	PRESSER BAR LIFTING LEVER SPRI	ヒザアケ テコ ハネ	1
10		B8101-191-0A0	KNEE LIFTER ASM.	ヒザアケ ソチ トリツケタ イクミ	1
11		B8102-191-0A0	KNEE LIFTER LEVER ASM.	ヒザアケ レハ - クミ	1
12		SS-9151210-TP	SCREW 15/64-28 L=11.8	ロツカクネ ルト 15/64-28	(1)
13		B8101-191-000	KNEE DRIVING SHAFT MOUNTING	ヒザアケ ソチ トリツケタ イ	(1)
14		B8511-180-000	SPRING	ヒザアケ ハネ	(1)
15		B3426-122-000	KNEE PRESS ROD THRUST BLOCK	ヒザアケ カイテントメ	(1)
16		SS-9182010-TE	BOLT 9/32-20 L=20	ロツカクネ ルト 9/32-20 L=20	(2)
17		B8514-180-000	STOP BLOCK	ネジ ツキ ストツハ-	(1)
18		SS-9661120-CP	SCREW 1/4-40 L=10.5	ロツカクネ ルト 1/4-40 L=10.5	(1)
19		110-24510	BRACKET	ヒザアテ タテジ クトリツケウテ	(1)
20		SM-9062053-SR	SCREW M6 L=20	ロツカクネ ルト	(2)
21		B3421-012-000	KNEE PRESS ROD	ヒザアテ ヨコジ ク	(1)
22		SK-3482500-SC	WOOD SCREW D=4.8 L=25	マルモクネジ D=4.8 L=25	4
23		B3419-552-0A0-A	KNEE LIFTER PLATE ROD ASM.	ヒザアテ タテジ ククミ	1
24		B3430-552-0A0	KNEE PRESS PLATE ASM.	ヒザアテ イタ クミ	(1)
25		B3431-552-000-A	KNEE PRESS PLATE COVER	ヒザアテ イタ カハ-	(1)
26		SS-9661120-CP	SCREW 1/4-40 L=10.5	ロツカクネ ルト 1/4-40 L=10.5	(1)
27		B3419-122-000	KNEE LIFTER PLATE ROD	ヒザアテ タテジ ク	(1)

7. THREAD STAND COMPONENTS

糸立装置関係

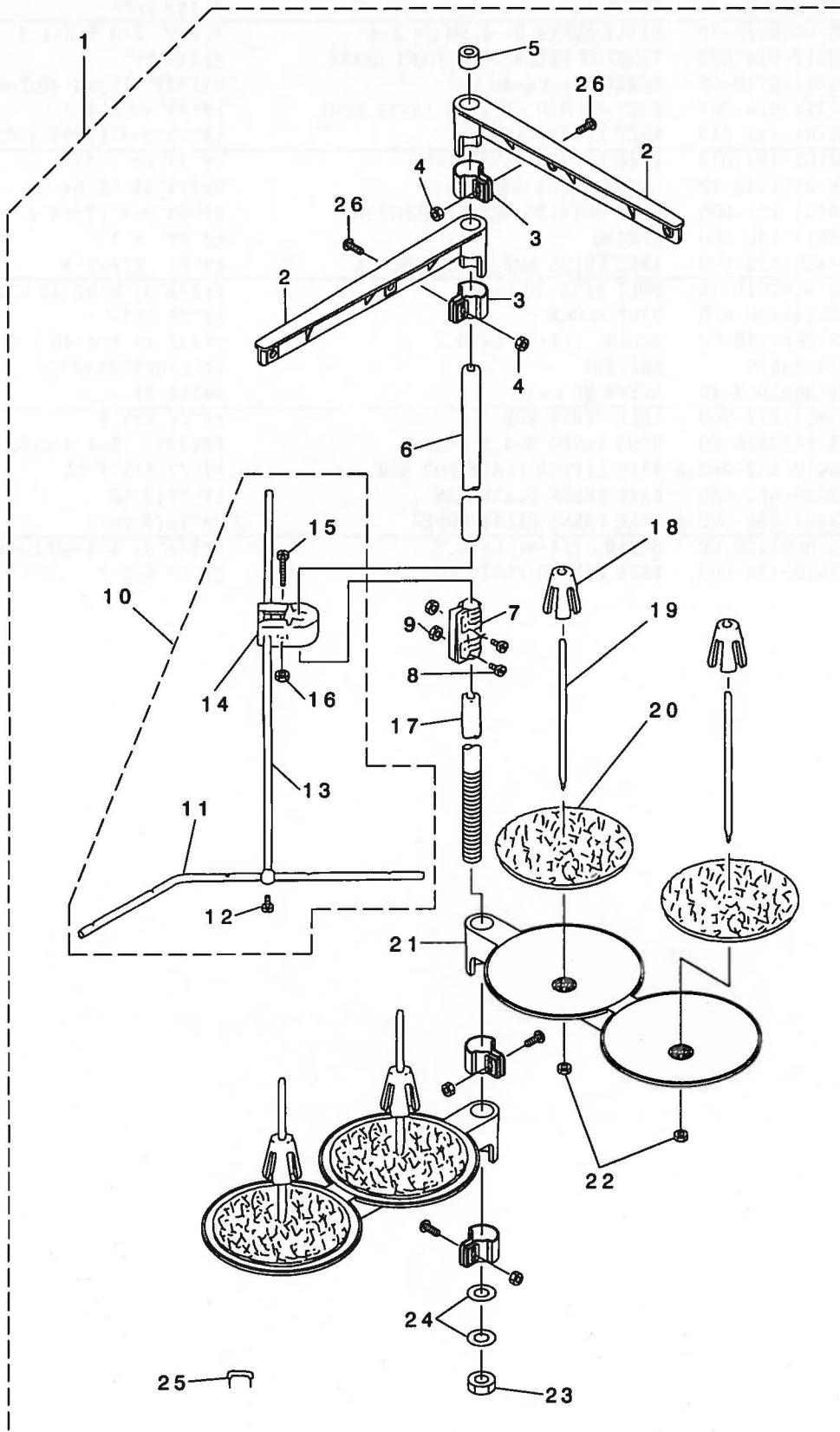

REF. NO	NOTE	PART NO.	DESCRIPTION	ヒソメイ	Qty
1		119-69458	THREAD STANDING DEVICE ASM.	イトタテソウチ クミ	1
2		111-85352	THREAD GUIDE ASM.	イトタテイトアンナイ クミ	(2)
3		111-85402	THREAD GUIDE ARM JOINT	イトタテウテ' シメカナク'	(4)
4		NM-6050001-SE	NUT M5	ロツカクナツト M5	(4)
5		B3311-704-000	SPOOL REST ROD CAP	イトタテホ' -キヤツブ'	(1)
6		111-85204	SPOOL REST ROD, UPPER	イトタテホ' ウ ウエ	(1)
7		B3305-704-000-A	SPOOL REST ROD JOINT	イトタテホ' -ツキ' テ	(1)
8		SM-4051405-SE	SCREW M5 L=14	ナハ' コネシ' M5 L=14	(2)
9		NM-6050001-SE	NUT M5	ロツカクナツト M5	(2)
10		B3309-704-OAO	THREAD GUIDE ARM ASM.	イトタテ イトアンナイ ウテ' クミ	(1)
11		B3311-804-000	LOWER THREAD GUIDE	イトタテ イトアンナイ シタ	(1)
12		SS-7110540-SP	SCREW 11/64-40 L=5	マルヒラネシ' 11/64-40 L= 5	(1)
13		B3309-704-000	THREAD GUIDE ARM	イトタテ イトアンナイ ウテ'	(1)
14		B3304-704-000-A	THREAD GUIDE ARM HOLDER	イトアンナイウテ' ホルタ' -	(1)
15		SM-6053000-SE	SCREW M5X0.8 L=30	ヒラコネシ' M5X0.8 30	(1)
16		NM-6050001-SE	NUT M5	ロツカクナツト M5	(1)
17		111-85105	SPOOL REST ROD, LOWER	イトタテホ' ウ シタ	(1)
18		111-85501	SPOOL RETAINER	イトマキ フレト' メ	(4)
19		B3320-704-L00-A	SPOOL PIN	イトマキウケホ' ウ	(4)
20		B3311-012-000	SPOOL REST CUSHION	イトマキウケザ'	(4)
21		111-85006	SPOOL REST ARM	イトタテウテ'	(2)
22		NM-6050001-SE	NUT M5	ロツカクナツト M5	(4)
23		B3317-704-000	NUT	イトタテホ' - トメナツト	(1)
24		WP-1612616-SE	WASHER 16X30X2.6	ヒラザ' ガ' ネ	(2)
25		MAO-11532000	CORD STAPLE	コート' ステツブ' ル	(3)
26		SM-4051405-SE	SCREW M5 L=14	ナハ' コネシ' M5 L=14	(4)

Description 品名		1		2		3		4		5		6		7		
		Gauge set (with finger guard)		Throat plate		Needle clamp asm.		Presser foot asm. (with finger guard)		Feed dog		Looper asm. (L)		Looper asm. (R)		
Needle gauge size 針番																
Code ゲージ 記号																
	inch	mm														
B	1/8	3.2	12923561	12923504	12926051	12927869	12932307	12941555	12940656							
C	5/32	4.0	12923660	12923603	12926150	12927968	12932307	12941654	12940755							
D	3/16	4.8	12923462	12923405	12925954	12927760	12932307	12941456	12940557							
E	7/32	5.6	12923769	12923702	12926259	12928065	12932307	12941753	12940854							
F	1/4	6.4	12923868	12923801	12926358	12928164	12932406	12941852	12940953							
H	5/16	7.9		12924007	12926457	12928354	12932802	12941951	12941050							

Description 品名		8		9		10		11		12		13		14		
		Lap seam folder asm.		Lap seam folder asm.		Lap seam folder asm.		Feed dog asm. (with Removing needle holder)		Looper needle guide (For Removing needle holder)		Throat plate (For chain off thread)		Feed (For chain off thread)		
Needle gauge size 針番																
Code ゲージ 記号																
	inch	mm														
B	1/8	3.2	MAM2950AAAA	MAM2960AAAA	MAM2970AAAA	12932653	12943007	12923306	12932208							
C	5/32	4.0	MAM2950BBAA	MAM2960BBAA	MAM2970BBAA	12932653	12943007									
D	3/16	4.8	MAM2950CCAA	MAM2960CCAA	MAM2970CCAA	12932653	12943007									
E	7/32	5.6	MAM2950DDAA	MAM2960DDAA	MAM2970DDAA	12932653	12943007									
F	1/4	6.4	MAM2950EEAA	MAM2960EEAA	MAM2970EEAA	12932752	12943007									
H	5/16	7.9			MAM2970GGAA											

Folder mark
フォルダ'-記号

M295 - Extra light-weight
 M296 - Light-weight (MS-1190 Standard equipment)
 M297 - Medium-weight (MS-1190M Standard equipment)
 The folder is not included in gauge set.
 For code H, throat plate, presser foot and feed dog
 for MS-19 are used.
 Also, exclusive needle guards (12943957) are necessary.

極薄物用
 薄物用 (MS-1190標準装備)
 中厚物用 (MS-1190M 標準装備)
 フォルダ'-はゲージセットには含まれません。
 Hゲージは、針板・押さえ・送りがMS-19タイプとなります。
 また、専用の針受12943957が必要です。

Description 品名		1		2		3		4		5		6		7		
		Gauge set (with finger guard)		Throat plate		Needle clamp asm.		Presser foot asm. (with finger guard)		Feed dog		Looper asm. (L)		Looper asm. (R)		
Needle gauge size 針番																
Code ゲージ 記号																
	inch	mm														
B	1/8	3.2	12980561	12980504	12926051	12982666	12983508	12941555	12940656							
C	5/32	4.0	12980660	12980603	12926150	12982765	12983508	12941654	12940755							
D	3/16	4.8	12980462	12980405	12925954	12982567	12983508	12941456	12940557							
E	7/32	5.6	12980769	12980702	12926259	12982864	12983508	12941753	12940854							
F	1/4	6.4	12980868	12980801	12926358	12982963	12983607	12941852	12940953							

Description 品名		8		9		10		11		
		Lap seam folder asm. フォルダ - (組)				Throat plate (For chain off thread)		Feed (For chain off thread)		
Needle gauge size 針番										
Code ゲージ 記号			M296		M297		針板 (空環対応)		送り歯 (空環対応)	
	inch	mm								
B	1/8	3.2	MAM2960AAAA	MAM2970AAAA	12980900	12983706				
C	5/32	4.0	MAM2960BBAA	MAM2970BBAA						
D	3/16	4.8	MAM2960CCAA	MAM2970CCAA						
E	7/32	5.6	MAM2960DDAA	MAM2970DDAA						
F	1/4	6.4	MAM2960EEAA	MAM2970EEAA						

Folder mark
フォルダ - 記号

M296 - Light-weight (MS-1190 Standard equipment)

M297 - Medium-weight (MS-1190M Standard equipment)

The folder is not included in gauge set.

薄物用 (MS-1190標準装備)

中厚物用 (MS-1190M 標準装備)

フォルダ - はゲージセットには含まれません。

From the library of: Diamond Needle Co.

NUMERICAL INDEX OF PARTS

索引

PART NO 品番	PAGE 頁	REF NO	PART NO 品番	PAGE 頁	REF NO	PART NO 品番	PAGE 頁	REF NO	PART NO 品番	PAGE 頁	REF NO
B1104-191-A0A	2	39	B2322-019-000	12	1	SM-4051405-SE	14	8	SS-8080310-TP	6	55
B1104-191-A0B	2	40	B2402-019-000	4	19	SM-4051405-SE	14	26	SS-8110310-SP	8	38
B1104-191-A0C	2	41	B2501-019-000	10	3	SM-6053000-SE	14	15	SS-8110310-SP	8	41
B1104-191-0AA	2	38	B2502-019-000	10	1	SM-9062053-SR	12	20	SS-8110410-TP	10	19
B1124-804-000	2	53	B2503-019-000	10	25	SS-1090510-SP	6	42	SS-8110410-TP	10	56
B1130-051-000	2	51	B2505-019-0A0	10	4	SS-2110920-TP	6	58	SS-8110410-TP	10	60
B1140-019-000	2	66	B3107-804-000	4	6	SS-3060410-SP	2	20	SS-8110422-TP	10	30
B1156-019-000	2	14	B3112-704-000	4	8	SS-3060410-SP	6	47	SS-8110510-SP	10	34
B1157-019-000	2	15	B3126-012-000	4	5	SS-3090610-SP	2	18	SS-8111160-SP	4	11
B1160-019-0AA	2	16	B3304-704-000-A	14	14	SS-4080620-TP	8	26	SS-8150310-SP	8	8
B1161-227-000	6	62	B3305-704-000-A	14	7	SS-4080620-TP	8	31	SS-8150410-SP	10	23
B1162-019-0AA	2	21	B3309-704-0A0	14	10	SS-4091010-SP	2	13	SS-8150410-SP	10	26
B1165-026-000	2	49	B3309-704-000	14	13	SS-4091010-SP	4	22	SS-8150710-SP	6	37
B1166-019-000	8	13	B3311-012-000	14	20	SS-4110815-SP	2	56	SS-8150710-SP	8	46
B1202-512-000	6	9	B3311-704-000	14	5	SS-4120915-SP	2	2	SS-8150710-SP	10	14
B1203-512-000	6	35	B3311-804-000	14	11	SS-5060410-SP	4	13	SS-8151150-SP	10	2
B1203-512-000	8	44	B3317-704-000	14	23	SS-5090420-SP	4	41	SS-8152030-SP	6	24
B1207-191-AB0	6	1	B3320-704-L00-A	14	19	SS-5090610-SP	2	23	SS-8660522-TP	6	22
B1207-191-A00	6	6	B3419-122-000	12	27	SS-5110810-SP	2	29	SS-8660610-TP	6	7
B1208-019-000	6	5	B3419-552-0A0-A	12	23	SS-5660440-SP	6	30	SS-8660610-TP	8	6
B1209-019-0A0	6	2	B3421-012-000	12	21	SS-5820540-SP	2	65	SS-8660610-TP	10	40
B1214-019-000	8	51	B3426-122-000	12	15	SS-6060220-SP	4	25	SS-9151210-TP	12	12
B1219-019-000	2	11	B3430-552-0A0	12	24	SS-6080410-SP	2	62	SS-9151440-CP	8	48
B1222-019-000	6	17	B3431-552-000-A	12	25	SS-6090510-SP	8	16	SS-9182010-TE	12	16
B1236-125-BA0	6	3	B3501-019-0A0	6	25	SS-6090910-TP	8	28	SS-9284043-CP	2	45
B1401-019-000	6	53	B3501-019-000	6	31	SS-6090910-TP	8	33	SS-9661120-CP	12	18
B1402-019-000	6	39	B3502-019-000	6	27	SS-6092120-SP	6	32	SS-9661120-CP	12	26
B1404-026-000	6	52	B3503-019-000	6	28	SS-6092120-SP	8	40			
B1408-038-000	6	4	B3504-019-000	6	26	SS-6110480-SP	2	42	TA-0850604-RO	2	64
B1409-019-0B0	6	49	B3508-019-000	6	29	SS-6110610-TP	4	43	TA-1250406-RO	2	4
B1411-019-000	6	14	B3510-019-000	6	12	SS-6110610-TP	4	64	TA-1250406-RO	2	5
B1412-038-000	6	13	B3512-191-000	2	47	SS-6110610-TP	8	49			
B1418-019-000	6	50	B3541-012-000	6	43	SS-6111610-SP	6	11	WP-0320501-SE	2	61
B1501-191-000-A	8	4	B3701-019-000	12	3	SS-6111610-SP	8	54	WP-0371016-SD	2	58
B1502-541-000	8	7	B8101-191-0A0	12	10	SS-6121840-SP	10	62	WP-0371016-SD	4	36
B1505-191-000	8	3	B8101-191-000	12	13	SS-6122030-SP	2	8	WP-0550800-SP	8	55
B1509-191-000	8	1	B8102-191-0A0	12	11	SS-6122510-SP	4	14	WP-1612616-SE	14	24
B1510-191-000	8	2	B8511-180-000	12	14	SS-6151220-SP	6	8			
B1534-816-000	4	55	B8514-180-000	12	17	SS-7080510-TP	10	11	107-04203	2	63
B1601-019-000	10	44				SS-7090520-SP	4	18	110-06004	8	5
B1602-019-000	10	42	CM-3002000-C1	2	73	SS-7090520-SP	8	23	110-18603	2	67
B1606-191-000	10	43	CM-3002000-01	2	72	SS-7090530-SP	4	32	110-24510	12	19
B1608-019-000-A	10	32	CM-3002001-A1	2	71	SS-7090530-SP	4	37	111-85006	14	21
B1610-019-000	10	29	CM-3002001-01	2	70	SS-7090530-SP	6	38	111-85105	14	17
B1621-261-000-A	10	57	CM-5003000-01	2	43	SS-7090710-SP	2	50	111-85204	14	6
B1622-541-000	2	33	CQ-2520000-00	6	48	SS-7090710-SP	2	59	111-85352	14	2
B1623-191-000	10	52	CQ-3030000-00	6	40	SS-7090850-SP	4	33	111-85402	14	3
B1624-191-000	10	48				SS-7090910-SP	6	51	111-85501	14	18
B1625-191-000	10	51	MAM-2950CCAA	8	52	SS-7090910-SP	8	20	115-03604	4	58
B1626-191-000	10	50	MAO-11532000	14	25	SS-7090910-TP	6	45	119-56703	4	9
B1634-191-000	2	36	MC-2630008-00	6	20	SS-7090920-SP	10	7	119-56901	4	10
B1635-191-000	10	20	MTV-640N1200	6	56	SS-7091110-TP	8	10	119-69458	14	1
B1635-191-000	10	41				SS-7110540-SP	14	12	129-20807	2	52
B1802-019-000	8	35	NM-6050001-SE	14	4	SS-7110710-SP	2	48	129-20955	2	1
B1803-019-000	8	36	NM-6050001-SE	14	9	SS-7110710-SP	2	68	129-21003	2	3
B1805-019-000	2	22	NM-6050001-SE	14	16	SS-7110710-SP	4	51	129-21201	2	9
B1806-019-000	2	24	NM-6050001-SE	14	22	SS-7110710-SP	4	60	129-21300	2	6
B1808-019-0A0	8	37	NS-6110310-SP	4	12	SS-7110710-SP	8	14	129-21409	2	10
B2001-019-000	10	24	NS-6110350-SP	4	50	SS-7110710-SP	12	8	129-21607	2	54
B2004-191-0A0	10	21	NS-6150310-SP	10	12	SS-7110830-SP	8	34	129-21805	4	52
B2006-019-0A0	10	18				SS-7110830-SP	10	17	129-21904	4	53
B2006-019-000	10	59	PS-0200082-KH	2	46	SS-7110840-SP	4	38	129-22001	4	54
B2101-191-000-A	10	38	PS-0250081-KO	10	49	SS-7110840-SP	4	56	129-22100	4	63
B2105-019-000	10	35	PS-0500202-KP	4	26	SS-7110840-SP	4	57	129-22357	2	25
B2106-019-000	10	36				SS-7111110-TP	10	5	129-22506	2	26
B2107-019-000	10	13	RE-0400000-KO	2	35	SS-7111110-TP	10	8	129-22704	2	19
B2108-019-000	10	33	RE-1200000-KO	8	47	SS-7111110-TP	10	22	129-22803	4	42
B2109-019-0A0	10	6	RO-0401002-10	2	34	SS-7111110-TP	10	45	129-23207	2	55
B2116-191-00A	10	9	RO-0611801-00	10	31	SS-7111120-SP	2	37	129-23306	6	63
B2116-191-00B	10	10	RO-0681901-00	2	28	SS-7111410-SP	4	29	129-23405	6	57
B2122-019-000	10	16	RO-0952001-00	10	37	SS-7120910-SP	6	15	129-24502	6	18
B2208-019-000	4	24	RO-0982401-00	6	33	SS-7151210-SP	2	12	129-24718	6	36
B2310-019-000	4	3				SS-7151210-SP	2	44	129-24718	8	45
B2317-019-000	12	7	SD-0450211-SP	12	6	SS-7621040-SP	10	28	129-24767	6	34
B2319-191-00A	12	4	SD-0790431-SP	12	2	SS-7740740-SP	2	27	129-24767	8	43
B2321-019-000	12	9	SK-3482500-SC	12	22	SS-7740740-SP	6	16	129-24809	6	10

From the library of: Diamond Needle Corp

N U M E R I C A L I N D E X O F P A R T S

索引

PART NO 品番	PAGE 頁	REF NO	PART NO 品番	PAGE 頁	REF NO	PART NO 品番	PAGE 頁	REF NO	PART NO 品番	PAGE 頁	REF NO
129-24809	8	53	129-81601	6	61						
129-24916	6	21									
129-25004	6	41									
129-25202	6	23									
129-25301	6	60									
129-25608	2	17									
129-25954	6	54									
129-27760	8	11									
129-29600	8	12									
129-31408	10	53									
129-31465	10	47									
129-31507	10	55									
129-31606	10	54									
129-31705	10	58									
129-31903	10	46									
129-32000	2	31									
129-32109	2	32									
129-32158	2	30									
129-32208	10	61									
129-32307	10	27									
129-33610	8	42									
129-33719	8	50									
129-34006	6	44									
129-34105	6	46									
129-34303	2	57									
129-34402	2	60									
129-35011	10	15									
129-35102	10	39									
129-35516	4	34									
129-35607	4	31									
129-35706	4	30									
129-35805	4	62									
129-35904	4	35									
129-36001	4	61									
129-36100	4	39									
129-36217	4	40									
129-36506	4	28									
129-36803	4	23									
129-36902	4	27									
129-37256	8	39									
129-37801	4	16									
129-37900	4	17									
129-38007	4	1									
129-38106	4	2									
129-38205	4	4									
129-38304	4	7									
129-38502	12	5									
129-38908	4	21									
129-39005	4	59									
129-39104	2	7									
129-39203	4	20									
129-39302	4	15									
129-39500	4	45									
129-39559	4	44									
129-39609	4	46									
129-39708	4	47									
129-39807	4	48									
129-39906	4	49									
129-40102	2	69									
129-40508	8	25									
129-40557	8	24									
129-41100	8	27									
129-41407	8	30									
129-41456	8	29									
129-42009	8	32									
129-42306	8	18									
129-42355	8	17									
129-42504	8	21									
129-42603	8	19									
129-42603	8	22									
129-42801	8	9									
129-42900	8	15									
129-43106	6	19									
129-43700	2	74									
129-80900	6	64									
129-81502	6	59									

JUKI®

JUKI CORPORATION
INTERNATIONAL SALES DIVISION
8-2-1, KOKURYO-CHO,
CHOFU-SHI, TOKYO 182, JAPAN
PHONE : 03(3430)4001-5
FAX : 03(3430)4909 4914 4984
TELEX : J22967

JUKI 株式会社

〒182 東京都調布市国領町8-2-1
TEL. 03-3480-1111(代表)

国内営業本部
TEL. 03-3480-1113(ダイヤルイン)

お問い合わせ、ご相談は
To order or for further
information,
please contact :

*このパーツリストは商品改良のため予告なく変更する事があります。

*The description covered in this parts list is subject to change for improvement of the commodity without notice.

*このパーツリストは、1996年10月現在の商品仕様で編集したものです。

*This parts list is edited in accordance with the product specifications as of October 1996.